



ULTRALOX



The UltraLox Interlocking  
ADVANTAGE

[www.ultralox.com](http://www.ultralox.com)



## OUR MISSION

Innovation is at the heart of our craft. To meet our customer requirements, we have developed a finite number of railing/fence models. Through flexibility and adaption, we strive to meet out-of-the-ordinary customer challenges, every day.

### OUR SPECIALTY

We take pride in adapting our products to meet customer requirements. UltraLox's products' offer a unique look which will enhance your property's appeal, all while respecting its original style. Quality products and professional service ensure the stellar reputation our company enjoys.

### ENVIRONMENTAL CONCERNS

- durable, maintenance free products
- entirely reusable products
- retrieval of used materials
- responsible management of waste on construction sites and in daily plant operations

### WARRANTEED PRODUCTS

All our aluminum products have a 15-year warranty against manufacturing defects. UltraLox applies a high quality powder coat finish according to AAMA 2604 specifications. This finish is guaranteed not to crack, chip, blister or peel for a period of fifteen years with normal use and weathering.

Installations within one mile of the ocean will require an upgraded AAMA 2605 Specified Powder coating to qualify for the above warranty.

# NEW CONSTRUCTION AND RENOVATION



UltraLox offers a multi-purpose solution. Our easy-to-install products are effective for new construction or renovation projects, no matter the size.

- we design and manufacture railing and fencing products
- replacement of existing railings
- repair or modification to balconies

Each project is supported by a professional team of engineers, architects, fabrication experts and installation teams, delivering turn-key solutions.

We collaborate directly with the client to ensure all specification requirements are met. Our adaptability allows us to develop unique solutions to supply maintenance – free deck and rail products which conforms to the North American Building Codes.



## COMMERCIAL PROJECTS

UltraLox supplies aluminum railings in both glass or picket for new construction or renovation of multi-level buildings. UltraLox will assist in your project from start to finish.

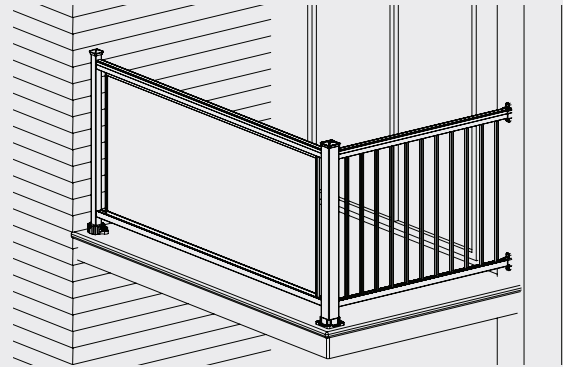

COLONIAL TOP RAIL  
 $\frac{1}{2}$ " X  $\frac{3}{4}$ " PICKETS OR 6MM GLASS

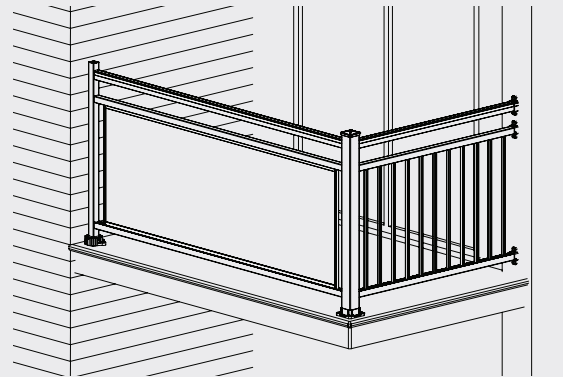

COLONIAL TOP RAIL W/OPEN MID-RAIL  
 $\frac{1}{2}$ " X  $\frac{3}{4}$ " PICKETS OR 6MM GLASS

Whether it is for the design of an original or customized railing system, our experienced, dynamic team will work hard to meet your design requirements. Choose from our stock powder coat finishes, custom color options or anodized finishes. It is all possible with UltraLox.

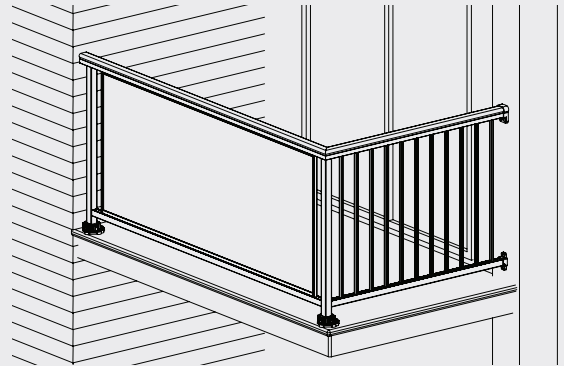

MISSION CONTINUOUS TOP RAIL  
1/2" X 3/4" PICKETS OR 6MM GLASS

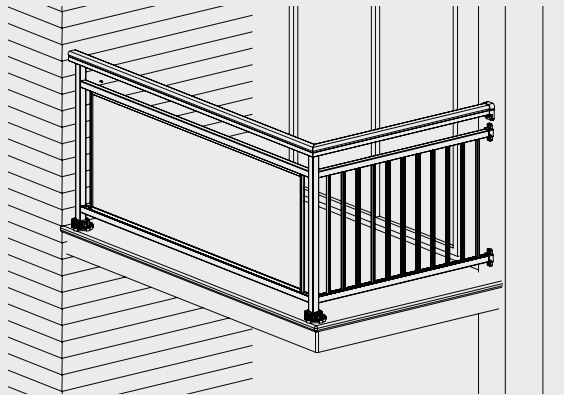

MISSION CONTINUOUS TOP RAIL  
WITH OPEN MID-RAIL  
1/2" X 3/4" PICKETS OR 6MM GLASS

## MULTI-FAMILY HOUSING CONDOMINIUMS & APARTMENTS

Multi-family housing projects are an integral part of UltraLox's business. However, apartments and condominiums differ from residential buildings because of their combination of intense usage and specific design characteristics. Construction features, such as common walls, abutting patios, shared entries and architectural design features such as customized railing designs, special attachment features and product substitutions, all play a part in the design and manufacturing of our products.

Through the development of our patented UltraLox-Interlocking machine and our growing dealer network, UltraLox is positioned to offer cost-effective railing products throughout North America. Approved dealers are positioned to manufacture UltraLox's products at the local level, ensuring quick turn-around times, eliminating shipping delays and freight damage. To ensure quality standards and compliance with UltraLox's stringent quality program, dealers are audited by a third-party independent inspection firm.



## RESIDENTIAL PROJECTS

UltraLox has developed a wide range of railings to suit our clients' taste and style. Our products are manufactured to specification and can be modified to meet specific needs. A feature that can enhance the appeal of your property and increase its value.



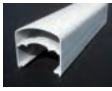

MISSION TOP RAIL/OPEN MID-RAIL  
1/2" X 3/4" PICKETS



COLONIAL TOP RAIL WITH OPEN MID-RAIL  
AND 1/4" TEMPERED GLASS

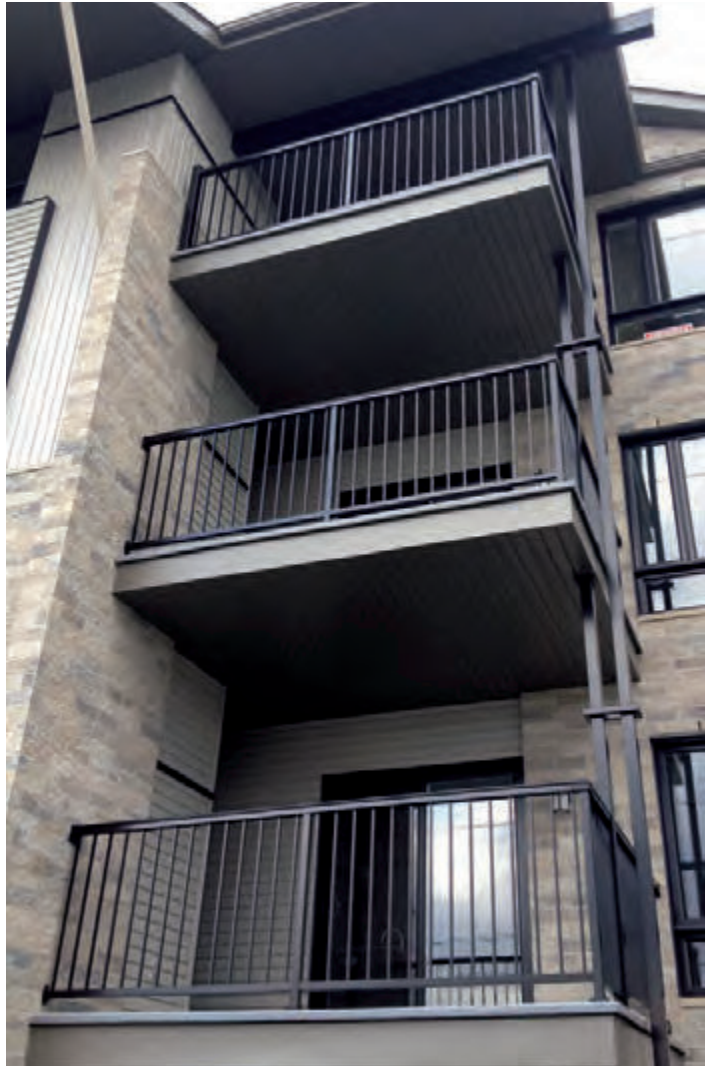

VICTORIAN CONTINUOUS TOP RAIL  
1/2" X 3/4" PICKETS



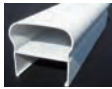

VICTORIAN TOP RAIL  
1/2" X 3/4" PICKETS



COLONIAL TOP RAIL  
1/2" X 3/4" PICKETS



MISSION TOP RAIL/OPEN MID-RAIL  
1/2" X 3/4" PICKETS

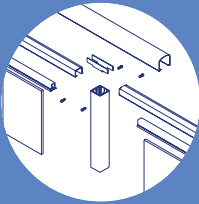

center detail

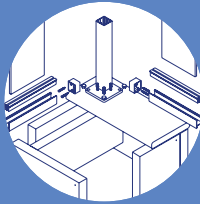

bottom detail

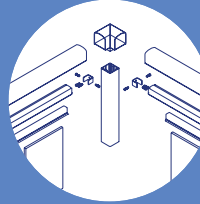

corner detail

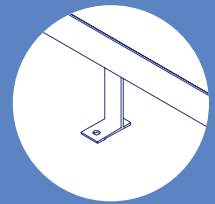

leg support

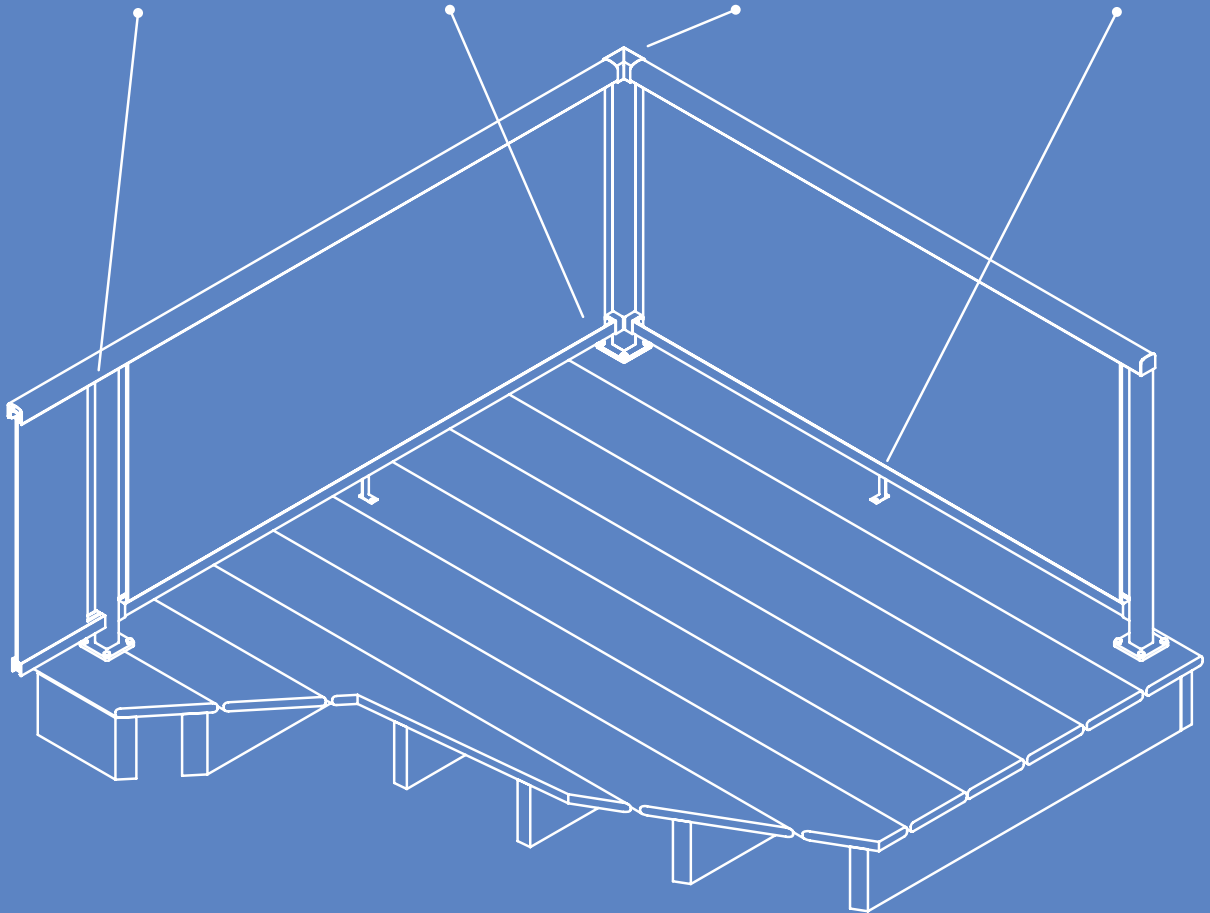

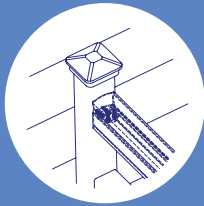

handrail attached to post

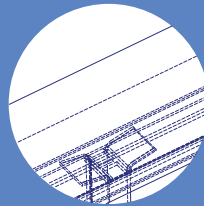

picket formed by UltraLox-Interlocking

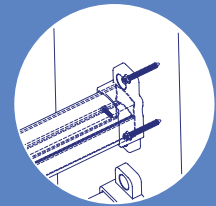

handrail attached to wall

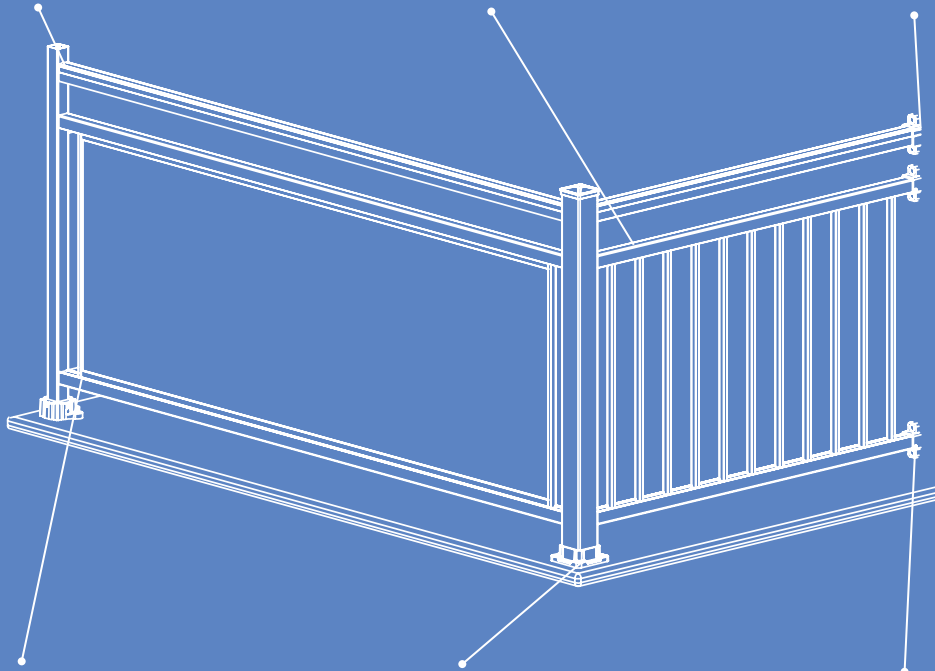

lower channel attached to post

3" post connect to deck floor

lower channel attached to wall

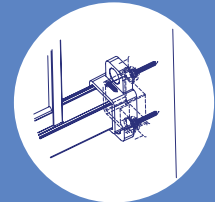
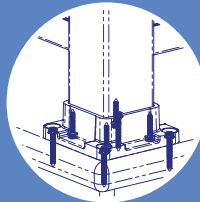
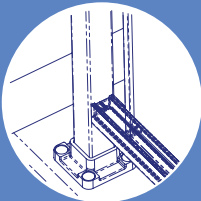

---

## RAILINGS

UltraLox manufactures a wide variety of aluminum handrails. UltraLox railings are designed to meet strength and resistance conforming to requirements of the North American Building Codes.

Through our ever growing network of dealers, UltraLox can supply standard aluminum railing systems which are manufactured by our Patented UltraLox Interlocking machine or we can supply custom fabricated railing and gates from one of our manufacturing facilities.

UltraLox aluminum railing systems have been successfully tested by third-party ISO 17025 testing laboratories in accordance with;

- ICC-ES AC273, Acceptance criteria for handrails and guards
- 2012 International Building Code (IBC)
- 2012 International Building Code (IRC)
- 2009 International Building Code (IBC)
- 2009 International Building Code (IRC)
- 2010 Florida Building Code (FBC) Including High Velocity Hurricane Zone (HVHZ) for Colonial and Victorian Series
- 2010 Canadian National Building Code
- 2012 Ontario Building Code
- 2012 British Columbia Building Code

Note: Certain posts and column models are not compatible with certain models of railings. Please check the specifications of the model. Other designs can be chosen by using different models of handrail, balusters or decorative accents.



---

## FENCES AND GATES

UltraLox offers aluminum fences and gates to enclose a pool area, ensure privacy or simply to enhance your property.

Our motto; Originality, strength, ease of installation and worry free maintenance.

Tempered glass panels or design accents enhance any one of our models. Heights up to 6 feet are available.



## ULTRALOX INTERLOCKING

A revolutionary machine that assembles aluminum railings and fence systems in minutes



UltraLox specializes in the aluminum guard rail and fence Industry as a supplier of the UltraLox Interlocking machine, which assembles the UltraLox aluminum railing and fence systems for use in commercial and residential decks, balconies, patios and pool surrounds. We work directly with building product distributors, fence companies and commercial contractors in North America.

The UltraLox Interlocking machine is the proven solution to reduce labor, inventory costs, warehouse requirements, freight cost and damage issues.

### INCREASE SAVINGS

- Fast order fulfillment
- Reliable accuracy
- Avoid handling and Transportation delays
- Quick Installation
- Reduce payment delays
- No Welding
- No Special Tooling

ULTRALOX INTERLOCKING  
A SMART INVESTMENT



Distributed By:

**Fence & Deck Connection**

1544 Whitehall Road, Annapolis, MD 21409,

Phone: 410-757-5511

Fax: 410-757-1094

[www.FenceAndDeckConnection.com](http://www.FenceAndDeckConnection.com)

[www.ultralox.com](http://www.ultralox.com)